

DESIGNING & MANUFACTURING IN THE UK SINCE 1923



# LIGHTING FOR PORTS

DESIGN | MANUFACTURE | INSTALL | MAINTAIN

**CU**  
**Phosco**  
LIGHTING

01920 860600  
[www.cuphosco.co.uk](http://www.cuphosco.co.uk)  
[www.cuphosco.com](http://www.cuphosco.com) (Int)  
[enquiries@cuphosco.co.uk](mailto:enquiries@cuphosco.co.uk)

**INTRO**

CU Phosco Lighting are the market leaders in the design, manufacture, installation and maintenance of High Mast lighting, specialising in Port Lighting. CU Phosco Lighting undertakes contracts at Ports worldwide, working closely with numerous large facilities including Southampton, London Gateway, Liverpool, Dover, Harwich, Immingham, Port of Tyne, Chile and the Philippines. Our High Masts and luminaires are present in the most demanding climatic conditions from typhoon winds in the South China Sea to the high temperatures of the Middle Eastern summer.

As a company we look after our customer from initial consultation through to installation, final commissioning and follow up maintenance. Our dedicated Contract Services Division is able to manage your projects in the UK, Europe and Worldwide. To achieve this we recognise the need to build honest relationships with our customers, to offer products at fair prices and importantly to support our customers on the use, maintenance and eventually replacement of our equipment.

This all adds up to a level of support which is unparalleled in the lighting industry.

To be confident in providing the quality and support our customers require, we manufacture products which meet the customer's technical performance and which are also appropriate for the environment into which they will be placed. Sometimes these aims are contradictory and it is then where the knowledge and experience of our staff is called upon by customers to ensure the best compromise of performance and durability is achieved.

Our Contract Services Division are an experienced team who are able to supply, install and maintain high masts using their own ASLEC and NICEIC certified personnel.

**DESIGN | MANUFACTURE | INSTALL | MAINTAIN**

CU Phosco Lighting offers customers who require it, a turnkey package. We will design the lighting scheme, check that all equipment to be supplied conforms to the specifications, design and arrange the installation of the foundations, design and install the electricity supply, manufacture the High Masts and luminaires, deliver the equipment, install the equipment and commission the equipment to confirm that the specification has been achieved.

CU Phosco's award winning LED products offer an innovative and energy saving solution to HID lit areas and highway lighting projects. We design, supply and install LED upgrade packages for existing projects to reduce energy and cost.

Our High Masts offer ease of maintenance with a simple and effective winching system which allows the lighting ring to be lowered to ground level for lantern maintenance.

CU Phosco Lighting believe that Health, Safety and the Environment are paramount across the breadth of the operations undertaken by our teams. All activities are carefully assessed by fully qualified managers and supervisors using risk assessments and method statements.

CU Phosco Lighting operates an Environmental Management System which complies with the requirements of ISO 14001:2004 for the testing and manufacturing, management of installation work, inspection and maintenance of exterior lighting. The system aims to recognise and reduce the impact on the environment.

High Masts, whether made by CU Phosco or other manufacturers, are substantial pieces of equipment and with proper maintenance they will last much longer than their design life. CU Phosco can check the structural soundness of any High Masts to confirm that they will be safe for extended use.

At the end of the design life of a High Mast the lanterns or floodlights, if original, will seem very out of date to a modern engineer. CU Phosco offer a refit service to bring old masts up to date by fitting new more energy efficient luminaires, checking and refurbishing or replacing the lantern ring, headframe, ropes, electrical cables and winches.

By implementing a structured maintenance programme in conjunction with CU Phosco Lighting you can ensure compliance with all current legislation and enhance the life of the equipment.

CU Phosco Lighting's own maintenance engineers are highly qualified and trained and are subject to a continual programme of training and development.

Outside of the UK we can train local engineers to maintain our High Masts so the products are safe and the lighting design delivers its full potential throughout its life.

**UK & INTERNATIONAL LED PORT LIGHTING INSTALLATIONS:**

ABP Southampton  
ABP Ipswich  
ABP Kings Lynn  
DP World Southampton  
London Gateway Port  
Port of Liverpool  
Dover Docks  
Great Yarmouth Port  
Birkenhead  
Harwich International Port  
Port of Sunderland  
Teesport  
Port of Immingham  
Port of Tyne  
Port of Blythe

Exolgan Port, Argentina  
Hutchisons Sydney Botany Bay, Australia  
Lynnterm Port, Vancouver, Canada  
Lirquen Port, Chile  
Coronel Port, Chile  
San Vicente Port, Chile  
APMT Poti Port, Georgia  
Tema Port, Ghana  
ICTSI OPC-Puerto Cortez, Honduras  
ICTSI, Manilla North Harbour, Philippines  
MICTSI Toamasina Port, Madagascar  
APMT Nouakchott, Mauritania  
APMT Tanger Med Port, Morocco  
APMT Apapa Port, Jordan  
Halden Harbour, Norway  
Setubal Port, Portugal  
Hamad Port, Qatar





**PORT OF SOUTHAMPTON**



|                 |                                      |
|-----------------|--------------------------------------|
| <b>CLIENT</b>   | Associated British Ports Southampton |
| <b>LOCATION</b> | Associated British Ports Southampton |
| <b>PRODUCTS</b> | FL800R LED Floodlight/P855 Lantern   |

**PROJECT OVERVIEW**

The Port of Southampton is a passenger and cargo port in the central part of the south coast of England. The port is owned and operated by Associated British Ports. It is one of the country's busiest deep-water ports and expands over 725 acres. Most of the large areas in the port are lit using high masts. The main objective of the project was to reduce the cost of illuminating and maintaining these high masts by converting them to more efficient LED products and installing fixed head lantern carriages to reduce maintenance costs further. CU Phosco Lighting were appointed as the main contractor following a successful tender submission.

CU Phosco Lighting undertook the lighting design utilising their in-house technical team. Once the lighting designs were approved by ABP, CU Phosco Lighting manufactured the luminaires at their lantern manufacturing facility in Ware, Hertfordshire. The replacement fixed head lantern carriages were manufactured in CU Phosco Lighting's manufacturing facility in Cleckheaton, West Yorkshire. CU Phosco Lighting undertook the supply and installation of the new LED lantern utilising their in-house specialist Contracts Division.

Telensa CMS nodes were installed in each lantern to provide additional control and reporting

**RESULTS AND BENEFITS**

The first phase of the project was completed to programme and the improvement in light quality from HID to LED is evident across the areas. The quality of the new lighting has also had a positive impact on health and safety in these operational areas. The LED replacement also ensured that each of the areas complies to the relevant lighting standards and this was confirmed in the commissioning phase of the project as CU Phosco undertook light tests in each area. The FL800R & P855 provide exceptional optical control minimising obtrusive light, without compromising the lighting performance. This was an important part of the project as some of the areas were adjacent to residential properties.

Following the successful completion of the project, ABP awarded CU Phosco Lighting a second phase of high mast LED replacement works.

Phase 1 – 83no Masts – 268no FL800R & 61no P855

Phase 2 – 34no Masts – 170no FL800R

**FACTS & FIGURES**

Estimated Energy Reduction of 48%



**PORT OF SOUTHAMPTON**



**PORT OF SOUTHAMPTON**

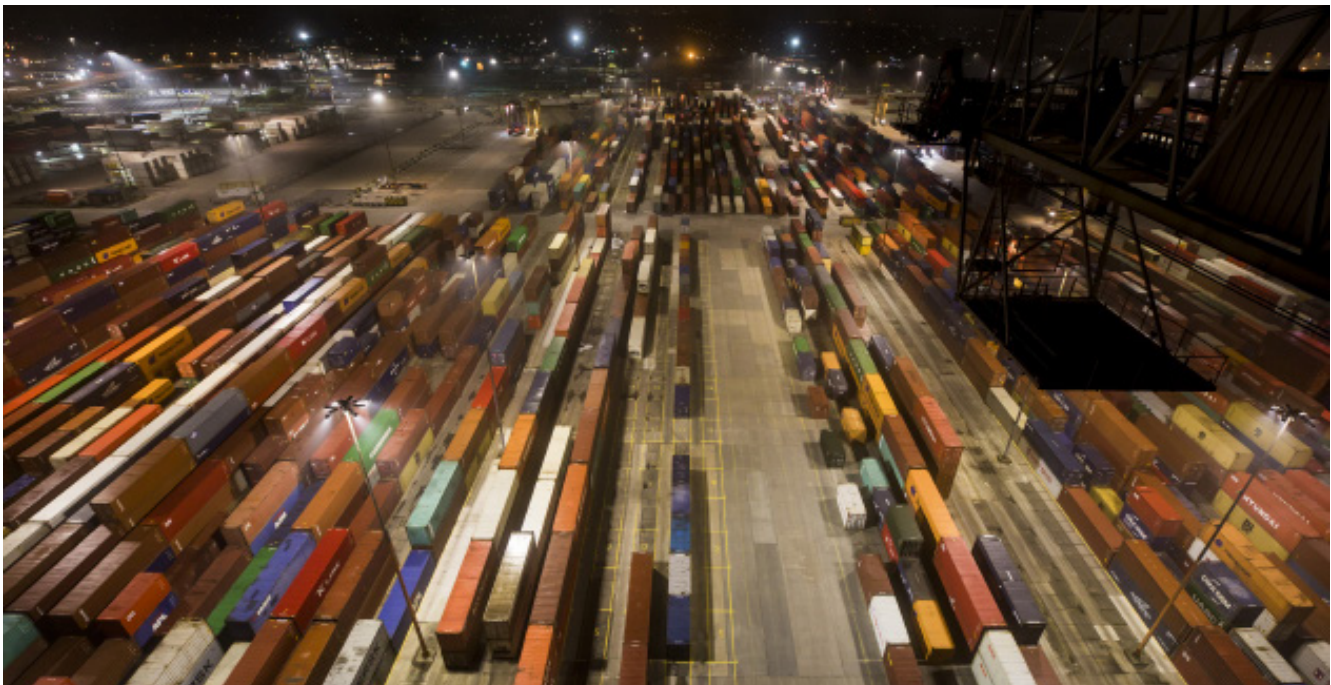



**LIRQUEN PORT**



|                 |                               |
|-----------------|-------------------------------|
| <b>CLIENT</b>   | DP World Lirquén, Chile       |
| <b>LOCATION</b> | Port of Lirquén, Penco, Chile |
| <b>PRODUCTS</b> | FL800R & WB 830               |
|                 | High Masts                    |

**PROJECT OVERVIEW**

Port of Lirquén is a cargo port, located about 550 kilometres south of Santiago de Chile, on the coast of Bahía de Concepción, VIII Region.

Given the continuous growth of the cargo to be transported, this port has been forced to increase its storage yards to accommodate the greater number of containers that such growth carries with it. The existing docks and container yards of this port were originally illuminated with masts and 1000 watt high pressure sodium luminaires, provided by CU Phosco Lighting in 1998.

As a result of the expansion of one of its container yards called "La Tosca", has expanded by more than 5.5 hectares. In order to improve the quality and performance of the lighting and to reduce both maintenance and energy costs CU Phosco Lighting proposed the use of FL8004-4 LED lights instead of the high pressure sodium luminaires.

CU Phosco Lighting undertook the lighting design utilising their in-house technical team, considering the requirement of an average lighting level of 50 lux, demanded by Lirquén, which was achieved with 40-meter high masts and FL800R-4 LED luminaires.

**RESULTS & BENEFITS**

CU Phosco Lighting presented a technical economic cost study comparing the use of LED lights versus high-pressure sodium ones, which concluded that the annual energy savings is 42% in favour of LED. Although the initial investment for LED lights was 57% higher than sodium lights at that time, the return on investment given the savings, was approximately five years.

Given these results, the Port of Lirquén approved and commissioned CU Phosco Lighting to carry out this project for the lighting of this extension utilising the FL800R floodlights.

The improvement in the quality of light by changing from sodium to LED is evident, and as a result the Port of Lirquén now plans the gradual replacement of its current sodium luminaires for LEDs in all its patios and docks.

Following the successful completion of the project two other ports located in the same region as Lirquén, Coronel Port and SVTI International Terminal, have contracted CU Phosco Lighting to provide both the high mast and floodlights.

**FACTS & FIGURES**

Estimated Energy Reduction of 42%



**HIGH MASTS**



**TAILOR MADE**

High Mast lighting is the most efficient method of lighting large areas at ports with the minimum number of obstructions. CU Phosco Lighting the world leaders in High Mast lighting, have achieved that distinction by continuous development, investment and innovation, working with numerous ports worldwide. Our experience is unequalled in the number of High Masts we have made and the many different environments in which we have installed them over the past 50 years.

CU Phosco High Masts are manufactured at our dedicated High Mast production facility in the UK.

**WHY CU PHOSCO HIGH MASTS?**

- To illuminate large areas with minimum obstructions
- For a complete design, manufacture and installation package
- High Masts can be used in confined spaces and do not require a large area to be cleared
- Unique patented double drum winch with individual adjustment possible on each drum
- Any height mast shaft from 10m to 60m manufactured by us to your specification
- Mast and fittings can be maintained at ground level for greater safety
- Minimum maintenance required with sealed for life bearings on mast pulleys
- Quick raising and lowering system
- Light and portable power tool which can be carried to inaccessible sites with ease
- Remote operation

**SIMPLICITY | RELIABILITY | SAFETY**

CU Phosco Lighting's design philosophy for High Masts is to eliminate all items requiring servicing from the mast head. It is for this reason we recommend the in-tension system, using double or triple drum winches.

CU Phosco's patented system.

- Supplied factory made and terminated - so no site cutting or termination of ropes is required.
- Has no troublesome divider or compensating device - as CU Phosco's system allows individual operation of each winch drum for adjustment
- Has pulley bearings at the top of the mast which are sealed for life - so no maintenance is required
- Does not require latches - no latches mean no moving parts at the top of the mast. High Masts are lowered and raised very infrequently and latching systems often do not unlatch whether due to corrosion, airborne debris or birds. Once the lantern ring is stuck on the latches at the top it is expensive to rectify either by sky tower or by taking down the mast. Latch designs do not hold the lantern ring tight against the docking point and wind induced vibration can severely shorten lamp and lantern life.

CU Phosco are confident that even after long periods without use, our raising and lowering system will function properly; a confidence founded on five decades of experience and tens of thousands of High Masts.

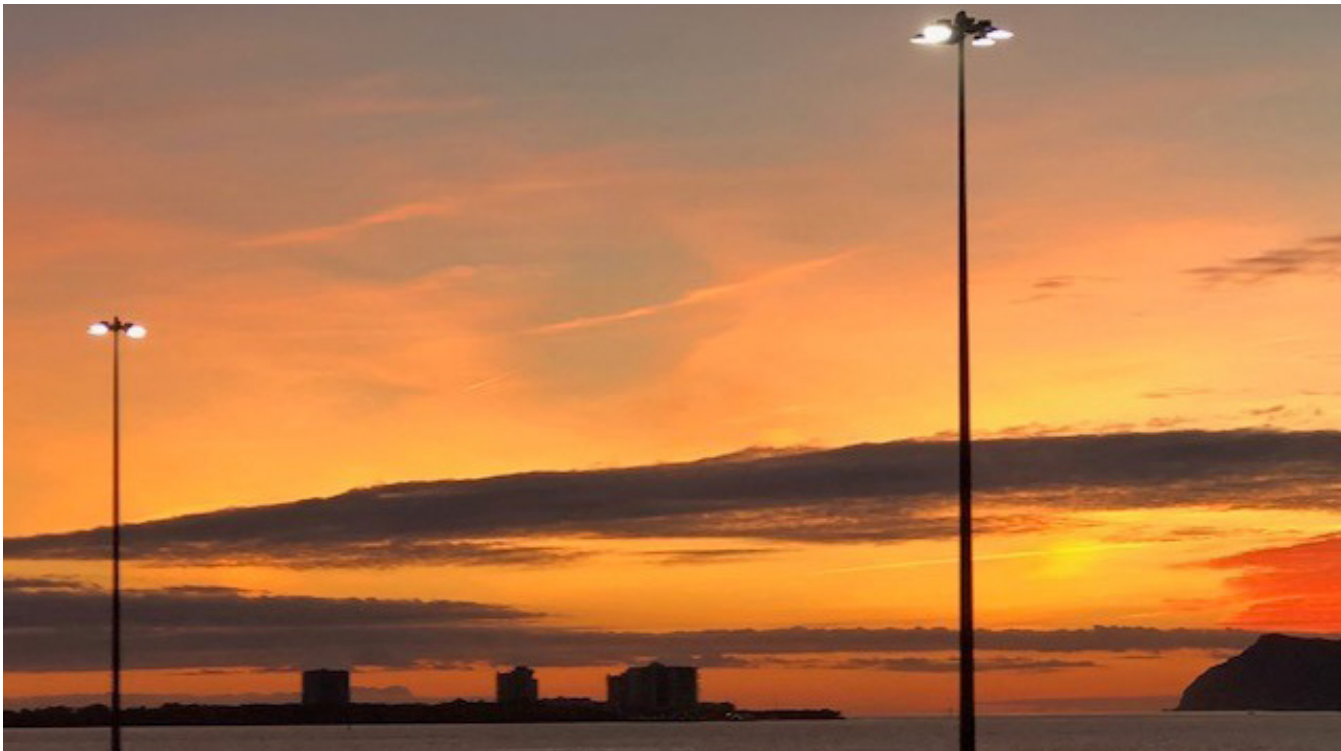

**FL820 AREA**



**INTRO**

**FL820-1**

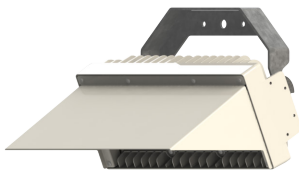

**FL820-3**

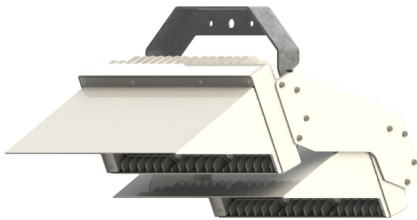

**FL820-3**

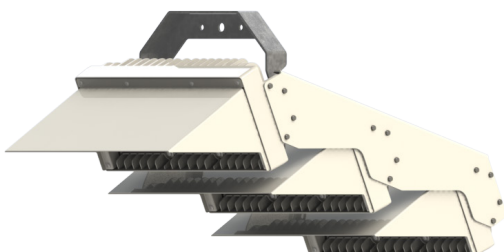

**FL820 LED FLOODLIGHTING SYSTEM** provides an innovative solution for Area Lighting.

The FL820 is a high output LED floodlight, which is designed for all types of area lighting, and may be used as a replacement for existing 1kW or 2kW floodlight systems. It is available as a single, twin or triple module with CSP (Chip Scale Package) LEDs.

**FEATURES & BENEFITS**

- High output up to 2000W replacement
- Superior luminaire efficacy up to 154lm / W
- High Colour Rendering Index
- Low glare, Dark Sky friendly
- Single Module and twin module Options
- CSP LED array for long life
- Can be mounted on existing columns and masts
- Integral driver box
- IP66
- Fully recyclable

|                                  |                          |
|----------------------------------|--------------------------|
| Max. Luminous Flux               | 70,000 lm per module     |
| Max. Luminaire Efficacy          | 154 lm/W                 |
| Luminaire Efficacy ( Full Power) | 137 lm/W                 |
| Lumen Maintenance                | L92 100Khrs 25°C         |
| Photometric Options              | 10 optical distributions |

**APPLICATIONS**

- Airports
- Ports
- Logistics
- Parking & Industrial Areas
- Roads and roundabouts
- Shopping areas



**ADVANCED HEAT SINK**

Cooling fins are optimised with a high surface area to quickly draw heat away from the LEDs. Vents created by the vertical cooling fins accelerate natural convection through the heatsink. The rising hot air draws cold air in from below, immediately cooling the LEDs and maximising their lifespan and light output.

This cooling effect allows the FL820 to function in ambient temperatures up to 50°C whilst ensuring it's high efficacy is maintained over life.

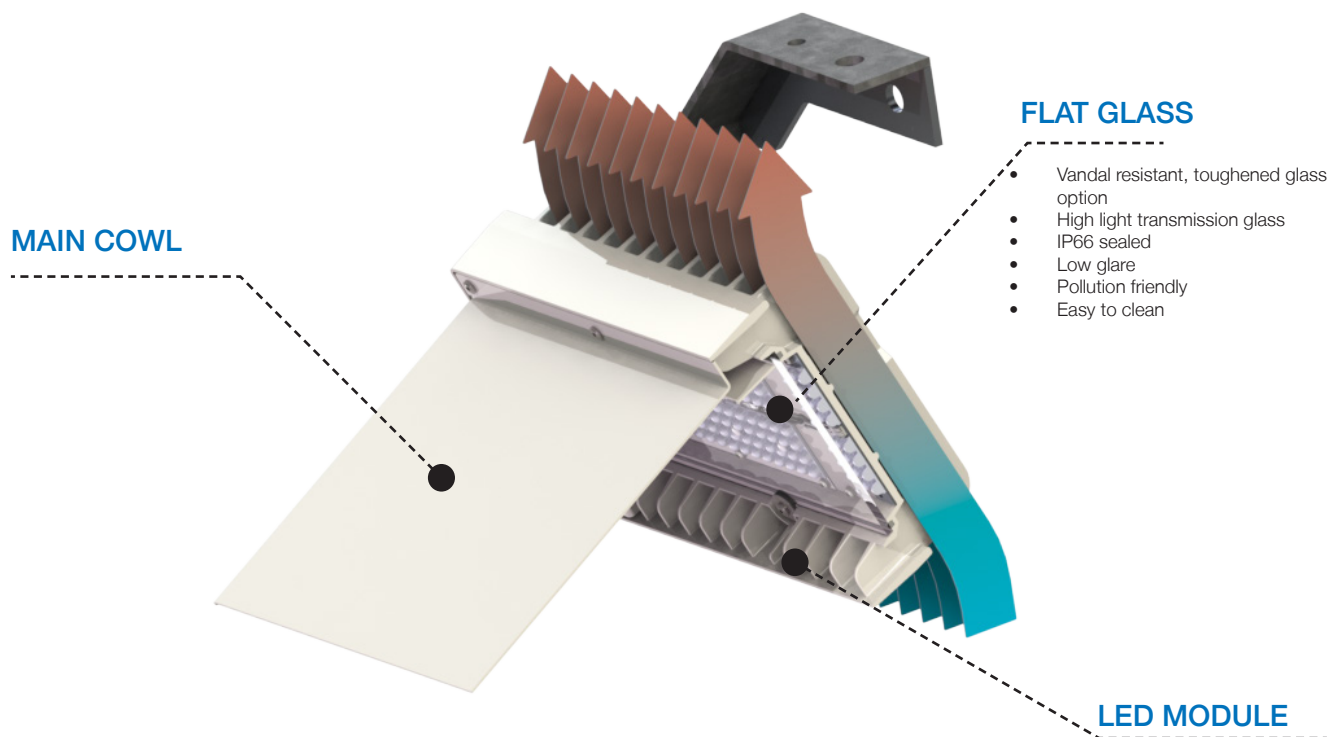

**ENERGY EFFICIENCY**

The table, on the right, shows indicative energy saving

| Light Source       | SON-T | FL810  | FL820-1                    |
|--------------------|-------|--------|----------------------------|
| Nominal Power      | 400W  | 625W   | 438W                       |
| System Power       | 449W* | 550W** | 422W                       |
| Number of Units    | 8     | 4      | 4                          |
| Total System Power | 3592W | 2200W  | 1688W                      |
| Energy Savings     | -     | 39%    | SON-T = 53%<br>FL810 = 23% |

**FL800D**

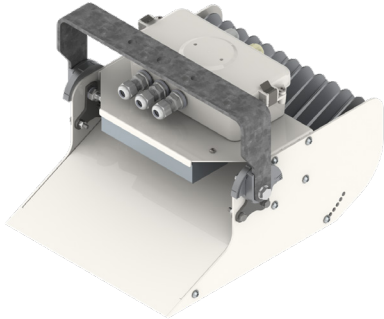

FL800D-1

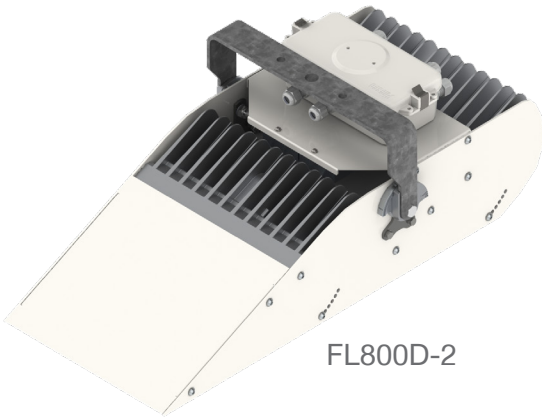

FL800D-2

**FL800D LED FLOODLIGHTING SYSTEM**

FL800D-1 or FL800D -2 can be arranged on a mast with full azimuth rotation and tilt function. These versions have drivers built in so are self contained.

Each module has a range of optical distribution options and a range of elevation angles to build a combined luminaire photometric output that meets even the most challenging of schemes.

FL800D uses AeroFlow® Cooling System to provide exceptional thermal management. Maximised heat dissipation enables a compact luminaire design, which can be retrofitted onto existing masts.

Lumileds LUXEON® MX LEDs and AeroFlow® together deliver high lumen output with very low lumen depreciation over life, this minimises energy and operating cost by reducing overlighting.

FL800D offers an extremely competitive solution to replace traditional HID sources with performance, versatility and reliability.

|                                       |          |
|---------------------------------------|----------|
| Max. Luminous Flux                    | 49760 lm |
| Max. Luminaire Efficacy               | 136 lm/W |
| Max. Luminaire Efficacy ( Full Power) | 115 lm/W |

|                              |
|------------------------------|
| L90 > 100,000 hrs, Ta = 25°C |
| L80 > 100,000 hrs, Ta = 45°C |

**APPLICATIONS**

- Airports
- Ports
- Sport facilities
- Logistics
- Car parks
- Roads and roundabouts
- Shopping areas

**FEATURES**

- Lumileds LUXEON® MX LED
- Superior luminaire efficacy - 136lm / W
- High Colour Rendering Index (CRI > 70)
- Constant Light Output (CLO)
- Instant hot restrike
- AeroFlow® Cooling System
- Low wind profile area
- Low maintenance costs
- Full Cowl, distribution cut off 5° below horizontal
- IP66 ingress protection
- 100% recyclable

**BENEFITS**

- High flux density and efficacy LED
- Reduces energy costs and carbon emissions
- Improved safety and visual performance
- Minimises overlighting, saving energy
- Suitable for high security and safety critical lighting tasks
- L80 @ 100,000 hrs, Ta = 45°C\*
- Flexible mounting allowing cost savings
- Allows mounting on existing columns / masts
- Minimises Total Cost of Ownership
- Dark sky friendly, minimal glare
- Consistant high performance in aggressive environments
- Fully compliant with WEEE and RoHS regulations

**ENERGY EFFICIENCY**

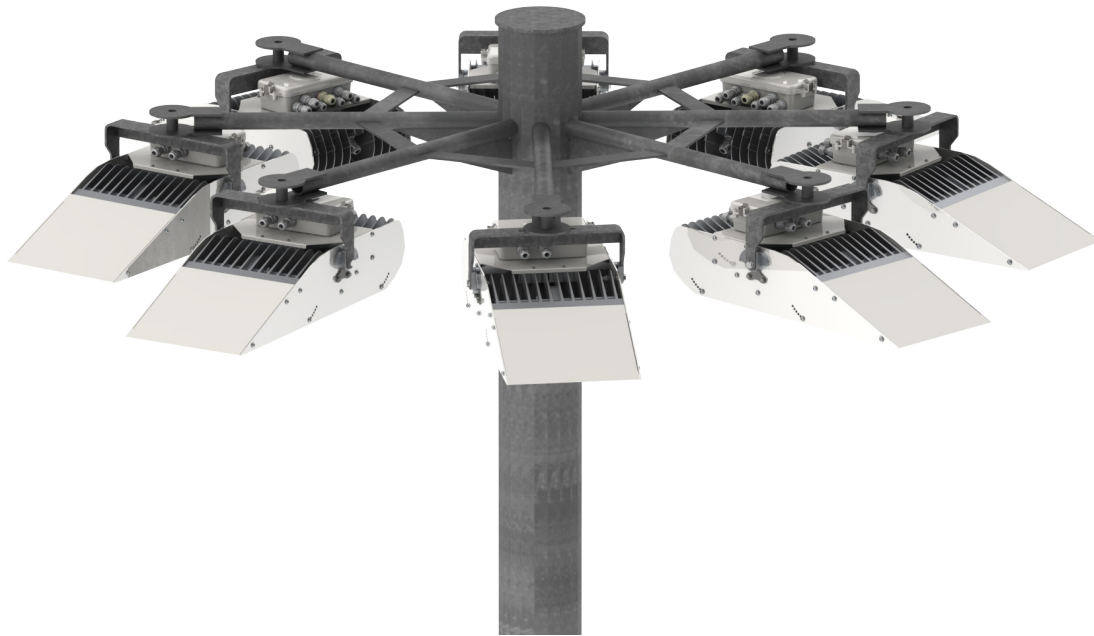

The table below shows indicative energy saving

| Light Source | Nominal Power | System Power | Number of Units | Total System Power | Energy Savings |
|--------------|---------------|--------------|-----------------|--------------------|----------------|
| SON-T        | 400W          | 449W*        | 8               | 3592W              | -              |
| FL800D       | 150W          | 143W**       | 16              | 2288W              | 37%            |

\* With electromagnetic control gear

\*\* Average power consumption over life with CLO for lumen depreciation MF = 0.90



**P855**

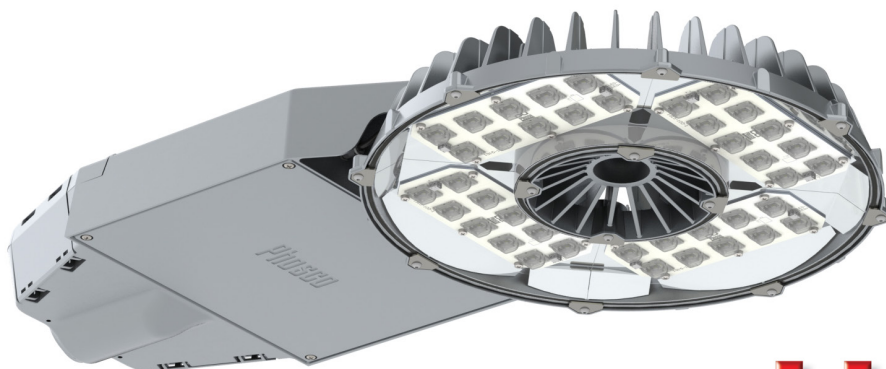

**INTRO**

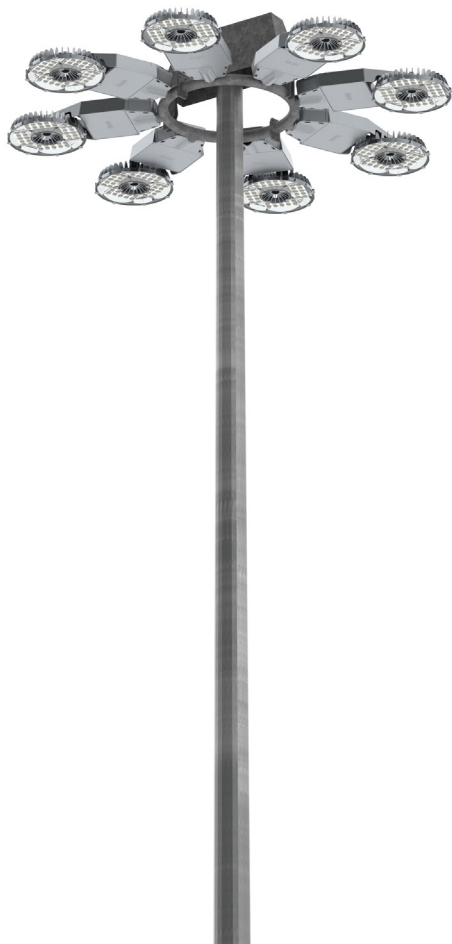

P855 is a highly innovative, High Mast LED luminaire with 360° rotating STAR-optic®. The functional yet compact design delivers exceptionally powerful optical and thermal performance, whilst maintaining a low weight and wind area.

whilst optimising energy efficiency for even the most challenging scheme.

It is the ultimate solution to replace traditional High Mast HID sources with superior efficacy and reliability.

P855's wide range of optical distributions coupled with 360° rotation delivers unlimited freedom in lighting design regardless of luminaire orientation,

|                                |                     |
|--------------------------------|---------------------|
| <b>WEIGHT</b>                  | 16kg                |
| <b>SIZE ( L X W X H )</b>      | 925 x 485 x 124     |
| <b>WIND AREA</b>               | 0.085m <sup>2</sup> |
| <b>LUMINAIRE LUMINOUS FLUX</b> | 36,000lm            |
| <b>LUMINAIRE EFFICACY</b>      | 103 - 126 lm/W      |
| <b>PHOTOMETRIC OPTIONS</b>     | 10+ Lenses          |

**BENEFITS**

- STAR-optic® system delivers 360° variable photometry
- Hybrid reflector + lens optic minimises light at angles near the horizontal
- Slim, elegant and state-of-the-art design
- High flux density and efficacy LED
- Powerful output up to 36,000 lm
- Superior luminaire efficacy up to 122 lm / W
- Wide range of light distributions
- Low lumen depreciation (L95 @ 90,000 hours) at full power
- User friendly installation
- Maximised savings on energy and maintenance costs
- Minimal total cost of ownership
- Up to G6 glare rating. Dark sky friendly, no upward light
- Flexible and intelligent lighting control options
- Lightweight and low windage allowing retrofit onto most existing masts
- IP66 ingress protection for Optical & Driver Compartment
- 100% recyclable, low carbon footprint

**THERMAL MANAGEMENT**

P855 is powerful while compact and efficient, thanks to its design and unique thermal management.

Aerodynamic vents created by the vertical fins at the center void are designed to accelerate natural convection. Hot air converges smoothly into a fast laminar flow, quickly removing heat from the luminaire, increasing the performance of LEDs and drivers.

Fin profiles are designed to minimise weight while allowing an even thermal dissipation for all LEDs.

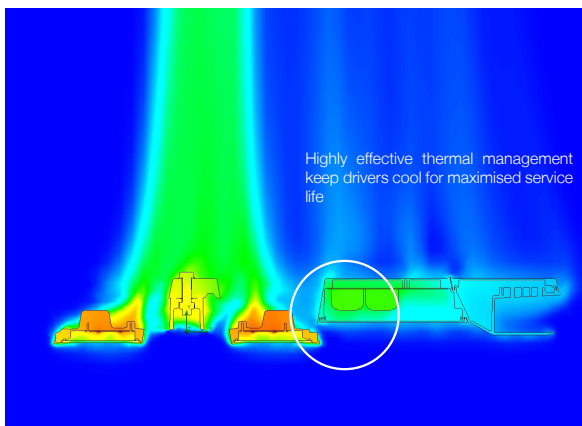

Air and luminaire temperature results from CFD

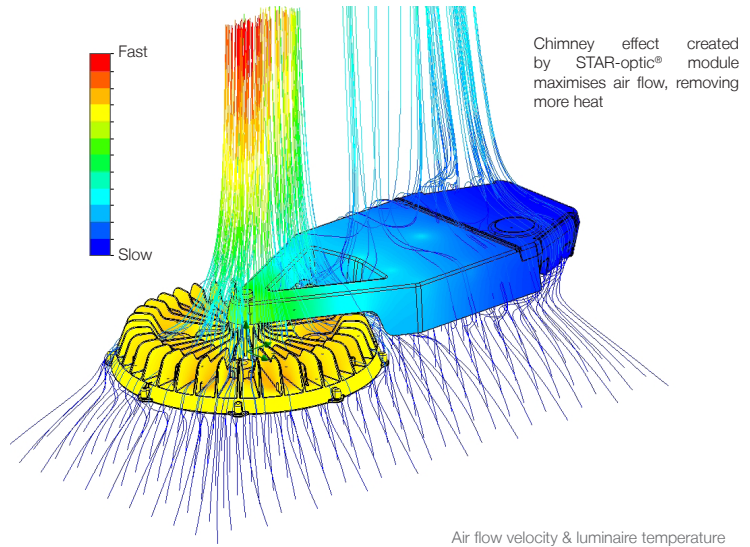

Air flow velocity & luminaire temperature

The complete separation of the driver compartment from LEDs keeps the driver very cool, significantly increasing the driver's service life in high ambient operating temperatures.

P855 can be used at maximum power in an environment of 45°C while still achieving low lumen depreciation and long life (L85 @ 100,000 hours)

**LIGHT DISTRIBUTION**

P855 offers a wide choice of optics and lumen packages. The optics include both road, flood and amenity distributions which, coupled with 360° rotation, allow even the most challenging schemes to be effectively lit with maximum energy efficiency.

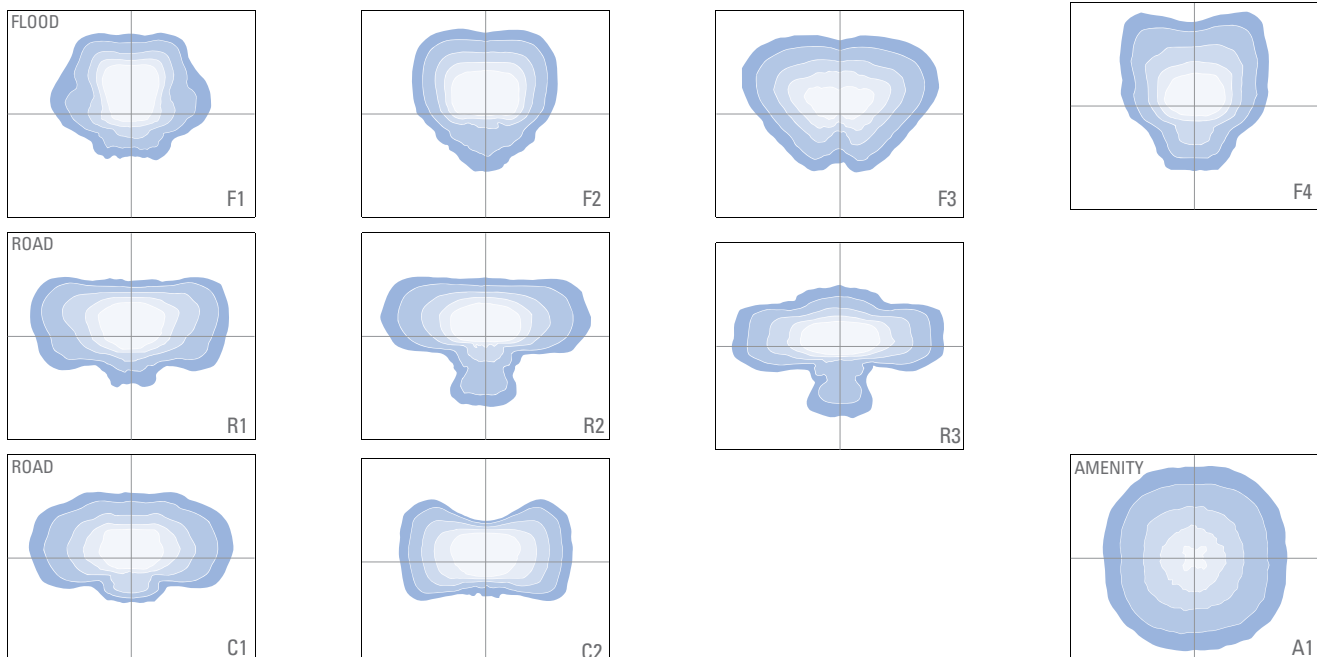

**DOHA PORT**



**SOUTHAMPTON PORT**

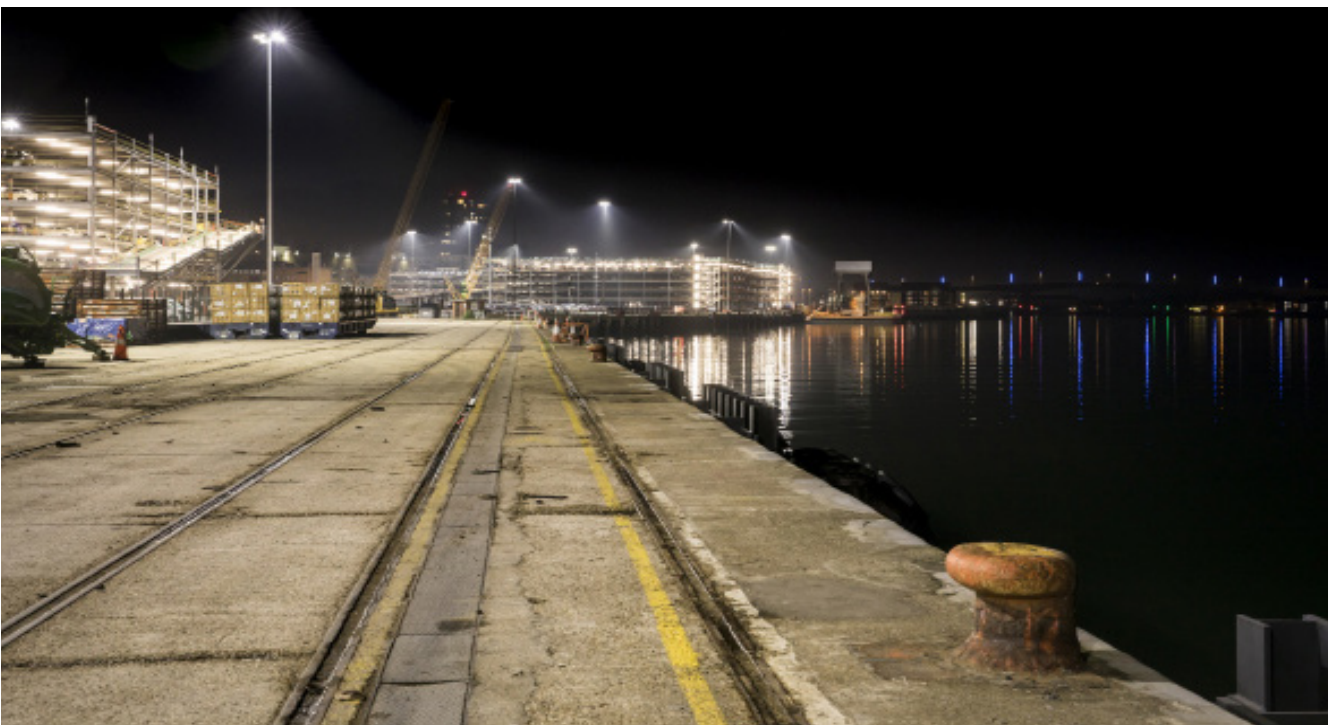



SOME OF OUR UK AND INTERNATIONAL CLIENTS

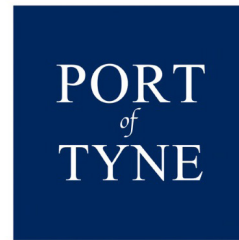

ACCREDITATIONS



DESIGNING & MANUFACTURING IN THE UK SINCE 1923

Copyright© 2020 CU Phosco Lighting. Due to constant product development, details in this brochure are subject to change .